

Small-Scale Hybrid Plant Integrated with Municipal Energy Supply System

Bjørn H. Bakken, PhD

Morten Fossum, MSc

Michael M. Belsnes, MSc

SINTEF Energy Research
N-7465 Trondheim, Norway
bjorn.bakken@energy.sintef.no

ABSTRACT

This paper describes a research programme started in 2001 to optimise environmental impact and cost of a small-scale hybrid plant based on candidate resources, transportation technologies and conversion efficiency, including integration with existing energy distribution systems. Special attention is given to a novel hybrid energy concept fuelled by municipal solid waste. The commercial interest for the model is expected to be more pronounced in remote communities and villages, including communities subject to growing prosperity. To enable optimisation of complex energy distribution systems with multiple energy sources and carriers a flexible and robust methodology must be developed. This will enable energy companies and consultants to carry out comprehensive feasibility studies prior to investment, including technological, economic and environmental aspects. Governmental and municipal bodies will be able to pursue scenario studies involving energy systems and their impact on the environment, and measure the consequences of possible regulation regimes on environmental questions. This paper describes the hybrid concept for conversion of municipal solid waste in terms of energy supply, as well as the methodology for optimising such integrated energy systems.

KEYWORDS: Energy distribution systems, Multi-objective optimisation, Waste fuel plant, CHP

1. INTRODUCTION

Due to environmental issues there is a growing interest for small-scale conversion of renewable sources and waste. Examples are local co-generation using commercial technologies, and more sophisticated solutions employing fuel cells or Rankine cycles with organic fluids. These new alternatives will offer an increased flexibility to system design and new possibilities to optimise an energy system subject to economy, energy efficiency and environmental aspects, but will also result in more complex solutions. Examples of situations with complex problems related to optimal co-ordination between different alternative energy carriers are: Development of a new suburb (including school, kindergarten, shopping centre, medical centre etc), design of new energy-efficient office buildings, or development of modern industrial areas.

When introducing new energy sources and technologies into the existing electricity distribution system it is necessary to take into account the interaction between the new source and the existing system. Dispersed electricity production raises a number of questions based on the needs of the consumer; both technical, economic and administrative. There is little dispersed generation installed in Norway today, but the amount is increasing, especially in connection with wind farms. It is expected that a larger amount of the electricity consumed will be produced locally in the future. So far technical issues like reliability of supply, power/voltage quality, protection and safety have been addressed only for traditional electricity supply systems where the generation capacity is centralized. If a larger amount of cogeneration units are installed, the amount of space heating by direct use of electricity will probably go down, leading to a shift in types of equipment connected to the network. Thus, new local energy technologies have to be carefully integrated into the existing energy/electricity distribution system.

During development of new methodology and models it is important with regular testing and verification with realistic data. This paper presents one of the selected test cases in the project; a small-scale waste fuelled cogeneration plant. Chapter 2 describes the cogeneration plant and the local energy system in general, and the waste treatment plant in more detail. Chapter 3 gives the outline of the analytic methodology under development, while Chapter 4 describes the hybrid optimisation algorithms to be used.

2. STUDY CASE: MUNICIPAL SMALL-SCALE WASTE PLANT PROJECT

2.1 Waste fuelled district heating system

In the county of Melhus 20 km south of the city of Trondheim, Norway, a small-scale cogeneration plant is being planned together with a local district heating network. The cogeneration plant is fuelled by municipal solid waste (MSW), and will supply 17 GWh/year heat to the district heating system and 6 GWh/year electricity to the local grid. The district heating network will have a total length of approximately 2 km, with the major customers of municipal administration and office buildings, local industry, schools and health care institutions within a radius of 500 m from the waste plant.

Currently, electricity is the major energy source in the area. The county is supplied with a meshed 22 kV grid from four supply stations to the regional grid with a total installed transformer capacity of 67 MVA. The current electricity consumption in the county centre is approximately 50 GWh/year plus some oil-fired space heating. The new cogeneration plant is planned with a heat capacity of 2 MW and a gas engine of 700 kVA electric capacity.

Assuming some new industrial customers to be connected to the district heating in the future, the cogeneration plant is expected to substitute 25-30% of current electricity consumption in the area. The installation will thus not have any major influence on the existing energy system.

2.2 Energy from waste technology

As a part of the initial phase to evaluate the possibilities for a local utilisation of MSW for the production of heat and power, the local energy distribution company *Melhus Energi* conducted a study where the available amount of MSW was found to be in the range of 5000 t/year. Commercial technologies for energy from waste for such small installations are scarce. The solutions are often based on gasification and pyrolysis while larger plants are based on combustion. In addition, manufacturers offering small-scale solution often have limited experiences with long term commercial operation of their technology.

Based on a total evaluation of cost, available MSW and possible technologies, *Melhus Energi* has chosen to implement the so-called *Pyroarc* process. The *Pyroarc* process is based on an updraft gasifier in combination with a decomposition reactor that also includes the use of plasma technology. The process is shown schematically in Fig. 1.

Solid waste is fed into the gasifier where the organic material is devolatilised and gasified to produce a

combustible gas. The inert materials in the waste, ashes and metals, are melted in the high temperature reaction zone.

The product gas is introduced into a mixing zone in the decomposition reactor just in front of the plasma generator. The dynamic forces of the plasma jet give an effective mixing of the plasma jet and the product gas. The product gas is partially oxidized in the decomposition reactor by addition of air or oxygen.

From the decomposition reactor the gas is led to a gas cooling and cleaning step which include removal of particulates, heavy metals and acid components. The gas cleaning system is designed according to local regulations for emissions.

Typical composition of the clean product gas is shown in Table 1.

Table 1. Typical clean product gas composition

Component	% (vol.)
CO	23.1
CO ₂	6.7
H ₂	17.6
H ₂ O	5.0
N ₂	47.6
SUM	100.0

The clean gas can be utilised in suitable combustion processes (boiler, gas engine, gas turbine etc) according to local requirements. At *Melhus* the gas is planned used in a gas engine for the production of heat and power.

The environmental benefits for the *Pyroarc* process compared to combustion are significant. As the gasifier operates at slagging conditions, the solid residues are very stable in terms of leaching compared to bottom ash from a combustion process. The solid residues from the gasifier can in fact be utilised as a product and not as a waste material that must be stored on landfills.

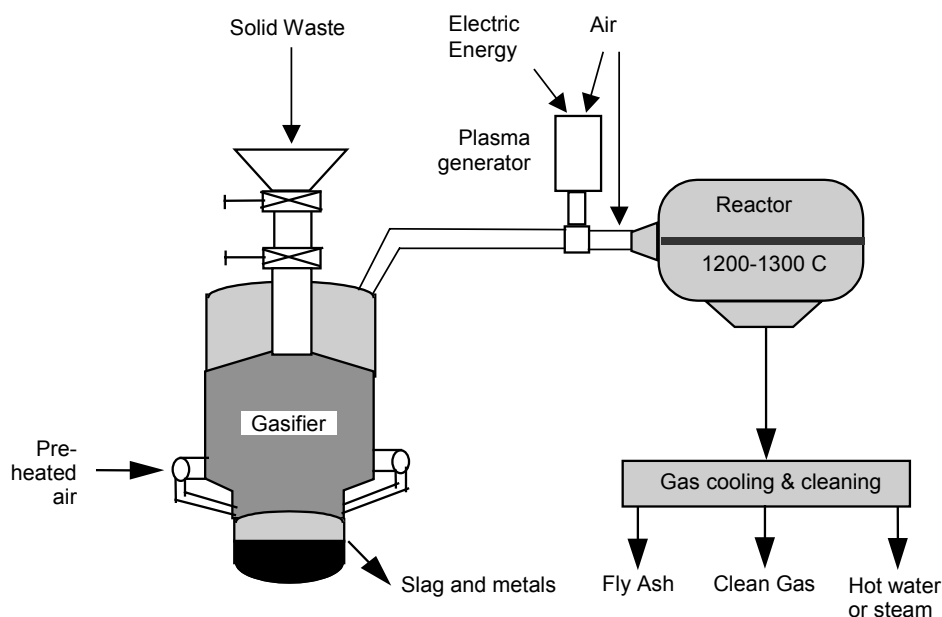

Figure 1. The Pyroarc process.

The product gas leaving the gasifier contains tars, chlorinated hydrocarbons and gaseous nitrogen components (NH₃, HCN). These components can cause severe environmental emissions like dioxins and NO_x and the tars can cause operational problems in combustion processes. However, the use of a plasma generator and the conditions in the decomposition reactor (high temperatures, good mixing and residence time), decomposes the components that can form these emissions. Measurements show that there is no recombination of halogenated hydrocarbons, and also the NO_x emissions are low due to reduced contribution of fuel NO_x.

The residues from the gas cleaning system can contain zinc and lead concentrations at levels that make recovery of these metals economically feasible.

The overall thermal efficiency for the Pyroarc process is in the range of 90-94%. The chemical energy in the product gas is typically in the range of 70-80% while the sensible heat of the product gas is in the range of 20-30%. For combined heat and power production in a gas engine, a net power efficiency of 20% can be achieved. This figure is based on an efficiency of the gas engine of 35% and subtraction of the power needed to operate the plasma generator. For larger units a steam cycle can be added, increasing the net power efficiency to about 35%.

3. ANALYSING COMPLEX ENERGY SYSTEMS

Generally, energy systems consist of three types of processes: Energy *transport* over a geographical distance (AC or DC lines, gas pipelines, LNG transport, district heating etc), *conversion* between different energy carriers (gas power plant, CHP, heat pumps etc) and *storage* of energy (batteries, LNG/gas tanks, heat storage etc). The general approach in planning an optimal energy system will be a multi-criteria decision problem where the objective is to find an optimal network of processes, based on the properties of the different processes.

To be able to do comprehensive analyses of complex local energy systems with several different energy resources, carriers and technologies, a robust optimisation methodology has to be developed. The main idea of this methodology is based on the knowledge and experience among electro-technical specialists on complex network structures, load flow models and linear programming. In this project, however, the concept is further developed from flow of electric current to generic *flow of energy*. Specialists from other fields are involved to model the different processes and components (Thermal energy, Refrigeration and Air Conditioning etc.). A major objective is to handle different components at different

geographical locations, connected by an energy distribution system.

As an example of this methodology a municipal multi-fuel heat and electricity distribution system is shown in Fig. 2. The figure is an illustration of which processes might be used in a county/region that uses combined heat and power supply based on biomass and waste fuel, and is more comprehensive than the actual study case as presented above. The main electricity and district heating networks are omitted from the figure for simplicity. Note that the presented Melhus project consists only of the waste fuel processes drawn above the dashed line.

Available energy resources are shown on the left in the figure: MSW from county and business offices, institutions, companies and households, gas from old land fills and biomass and waste from forestry and farming. These energy resources have to be transported, processed and stored; at different locations and in different forms before being converted to end user energy like electricity and heat. Often a choice has to be made between building larger centralized CHP units feeding electricity and district heating networks, or remote mini-CHP installations in single buildings like offices, schools, health care centres etc.). The model will treat energy transport by pipeline and power line as well as by road.

The following methodology is to be used:

- Based on a library of available components, the user builds a model of the distributed energy system with the alternative solutions to be optimised as shown in Fig. 2.
- Each component is internally modelled with the necessary mathematical details to account for the specific properties of that technology.
- The connection to the geographic energy network, however, is made by a simple and unambiguous set of linear variables like cost, energy efficiency and energy quality/environmental aspects.
- The superior network analysis and optimisation is made on a generic nodal model as shown in Fig. 3 without specific knowledge of which components are involved. At this level, the optimisation algorithms see only a linear network with nodes and branches where energy flows. This generalization occurs internally in the optimisation, and will not be noticeable by the user.
- For presentation to the user, the results are “translated” back to the component specific system model of Fig. 2.

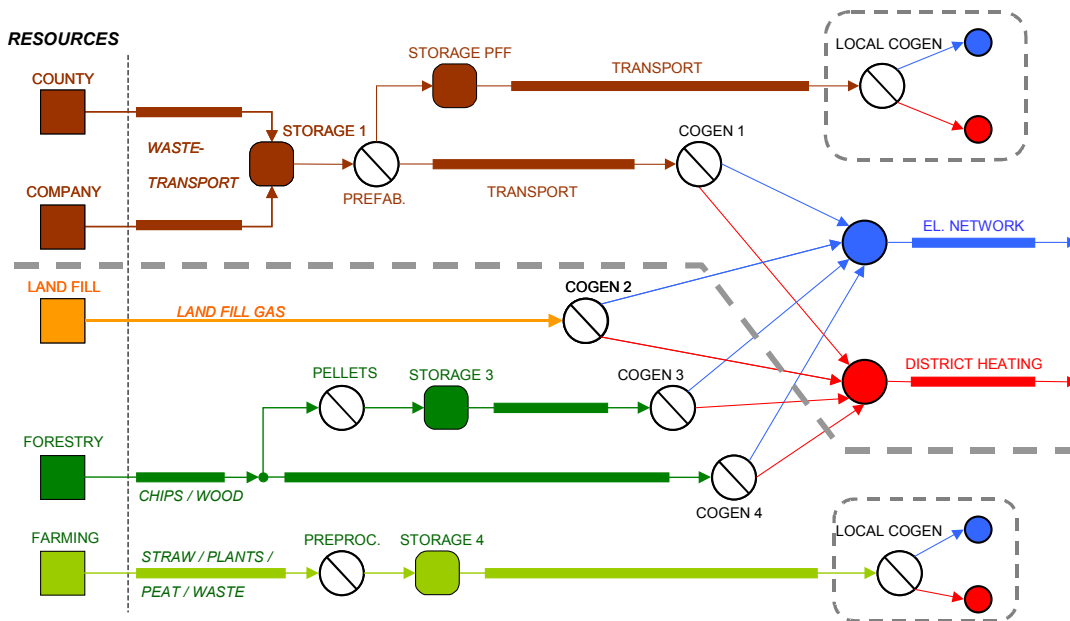

Fig. 2 Simplified municipal energy system model

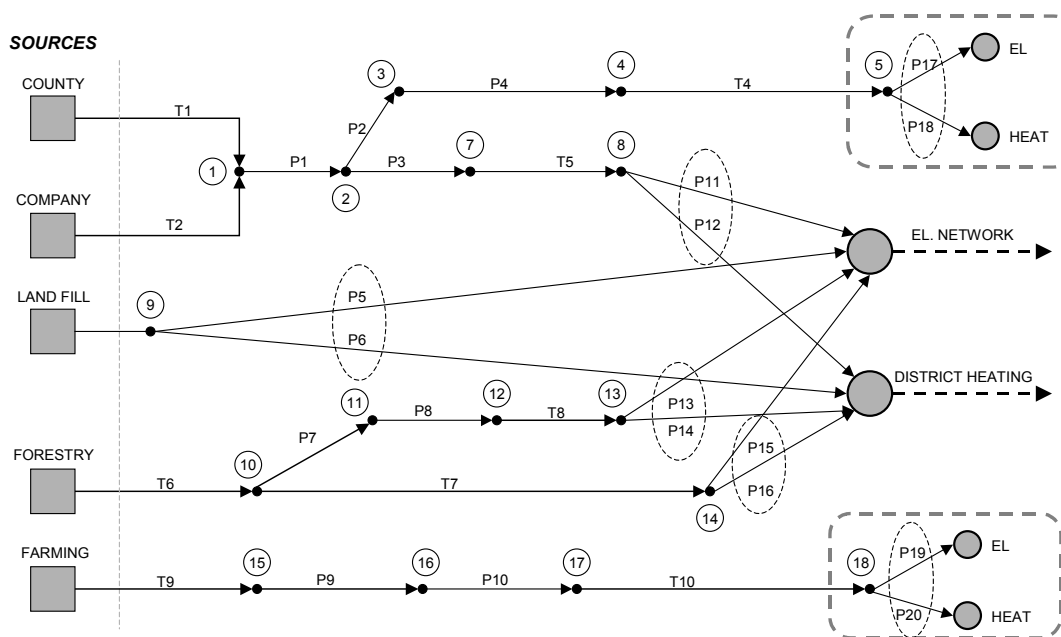

Fig. 3 Generic energy network model

4. HYBRID OPTIMIZATION TECHNIQUES

A major challenge when analyzing such complex energy systems is to combine the multi-criteria objective with the modeling demands of a variety of different energy processes. Adding the complexity and time span of the investment analysis creates an optimization problem not easily solved using conventional methods.

In this approach an important goal is to reduce the number of manual assumptions by separate modeling of each energy technology in sufficient detail. It is easy to argue against such an approach because some simplifying assumptions have to be made in any case. It is impossible to account for all physical aspects in one

model due to the different properties of the processes involved. The reason why this approach is able to obtain these goals without compromising the main physical characteristics of the processes involved, is the option of combining different optimization methods.

Combination of different optimization methods adds new possibilities to the modeling of the energy related problems. It is not necessary to account for everything in one large model, as input from other models can be used in the areas where the “all-in-one models” meet limitations. An example of such a successful hybrid approach, is a model that combines the long-term hydropower operation strategy calculated with stochastic

dynamic programming with a detailed deterministic sub-problem within one week [1]. It is not possible to account for every aspect of the hydropower system when calculating the long-term strategy. In order to calculate a long-term strategy one needs to aggregate in time such that start up cost, time delays and hydraulic couplings are not properly accounted for. This makes the results less useful if the modeled system does not meet certain assumptions. Typical assumption for aggregated hydro power models are zero start-up cost, intermittent operation allowed for pumps, limited system size and a non sequential time description. In many problems, however, these properties can be accounted for when another model is used for implementing the strategy. Adding the results from the long-term strategy as boundary conditions to a deterministic linear model makes it possible to account for the properties that cannot be included in stochastic optimization. This combination of methods makes it possible to handle details in a proper way despite of the inability of the strategy calculation to handle every hydropower detail.

This approach can be useful also in the case of energy distribution systems with multiple energy carriers. Detailed process models are created to account for properties that are difficult to combine without simplifying assumptions. The basic principles are shown in Fig. 4. A transmission model of either AC or DC power including security constraints is used for the local electricity distribution system. Special models for truck transportation to and from waste plants are used, as well as a district heating model which can optimize operation of the district heating system taking non-linear elements into account. An adequate model for hydropower to account for stochastic elements can also be used if there is hydropower in the region. Results from the component models are afterwards used in the linear system model to calculate the optimal operation plan for the selected time period (day/week) for a given topology alternative.

The optimal operation planning kernel as shown in Fig. 4 must be integrated with an investment analysis scheme to choose the best possible expansion plan over the planning horizon. So far dynamic programming has been used to find the best expansion plan according to the given alternatives and possible introduction times. The overall concept can then be outlined as in Fig. 5. In this concept the operation planning kernel is used for calculation of the running expense for the different alternatives. Results from each alternative are added to the dynamic programming table and the best route through alternatives (size and type) and time is calculated. Sensitivity and robustness of the alternative can be just as important as the profit of the investment, so a combination of criteria must be used for finding the best solution.

To be able to handle a hybrid model like this, it is important that the operation planning kernel is fast, because this calculation is the most time consuming. Also, the number of alternative topologies of the local energy system (new or expanded components, processes, transport channels etc.) will influence greatly on the

calculation time, hence it is important that the number of alternatives as specified by the user is limited. In most cases it will be possible to rule out the most unrealistic alternatives before optimization.

The design of the Graphical User Interface (GUI) is not yet specified, but integration with existing Geographic Information Systems (GIS) is a possible alternative.

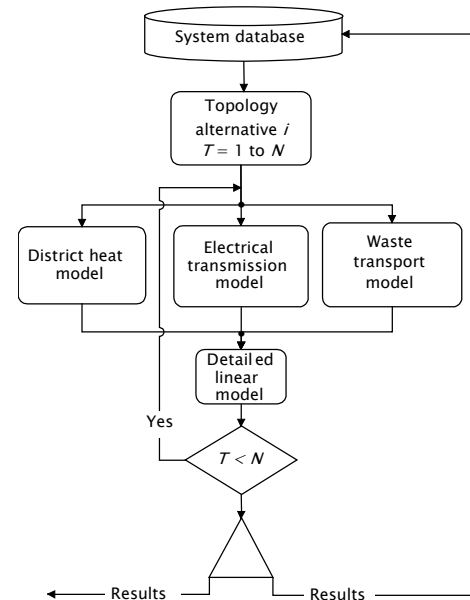

Fig. 4 Operation planning kernel with linear modeling

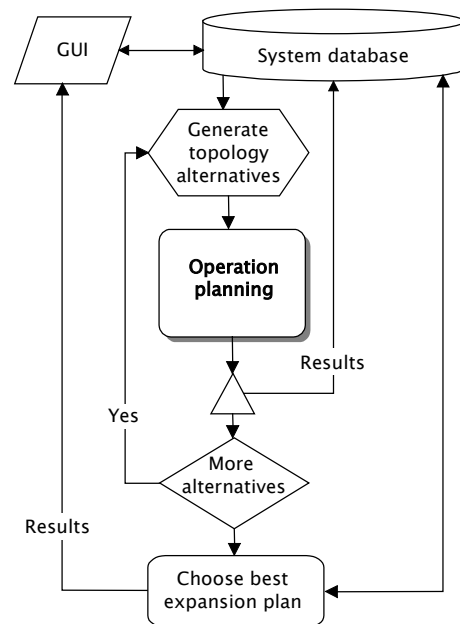

Fig. 5 Investment analysis integrated with operation planning kernel

5. CONCLUSIONS

This paper outlines the development of a new methodology for analysis of complex energy distribution systems with multiple energy carriers. The methodology is based on two main levels of modelling. The lower level is used to calculate optimal operation of the system and the upper level handles the investment decisions. In the Graphical User Interface specific component modules with a standard interface are combined in alternative compositions of the energy system. Each alternative is then generalized to a nodal network with generic energy flow. To enable a multi-criteria optimisation with a minimum of simplifying assumptions, which might limit the validity of the results, hybrid optimisation techniques will be implemented, e.g. combinations of stochastic dynamic programming and deterministic short-term optimisation. Each energy technology is modelled separately with sufficient detail, supplying the superior linear system model with a simple and unambiguous set of variables like cost, energy efficiency and environmental impact. The methodology will enable energy companies to carry out comprehensive analyses of their energy supply systems, and governmental bodies will be able to do comprehensive scenario studies of energy systems with respect to environmental impacts and consequences of different regulating regimes for preserving environmental values.

6. REFERENCES

- [1] A. Haugstad, B. Mo, M.M. Belsnes: "Evaluating expansion or refurbishment in a deregulated electricity market," Proc. of Hydropower '97, Trondheim, Norway

ACKNOWLEDGEMENTS

The authors wish to thank EnviroArch Technologies AS, Oslo, Norway, for providing technical data and information about the PyroArc process.

BIOGRAPHIES

Bjørn H. Bakken received his M.Sc. in electrical engineering from the Norwegian Institute of Technology (NTH) in 1989 and PhD from the Norwegian University of Science and Technology (NTNU) in 1997. He worked as a senior engineer at a municipal power company 1990-92. He is currently working as a Research Scientist at the Dept. of Power Transmission and Distribution Systems at SINTEF Energy Research in Trondheim, Norway.

Morten Fossum received his M.Sc. in mechanical engineering from the Norwegian Institute of Technology (NTH) in 1986, and started working at SINTEF Energy in 1987. He is currently working as a Research Scientist at the Dept. of Thermal Energy at SINTEF Energy Research in Trondheim, Norway.

Michael M. Belsnes received his M.Sc from the Technical University of Denmark in 1995. He has been working at SINTEF Energy Research since graduation, and is currently working in the Dept. of Power Generation and Market